

Pump Pompa	Pressure Pressione		Volume Portata		RPM giri/min	Power Potenza	
	bar	PSI	l/min	GPM		HP	kW



PUMP INLET: G 3/8" F
optional 3/4 FGH

PUMP OUTLET: G 3/8" M
optional FEMALE QUICK
COUPLING

Dimensioni d'ingombro

Overall dimensions

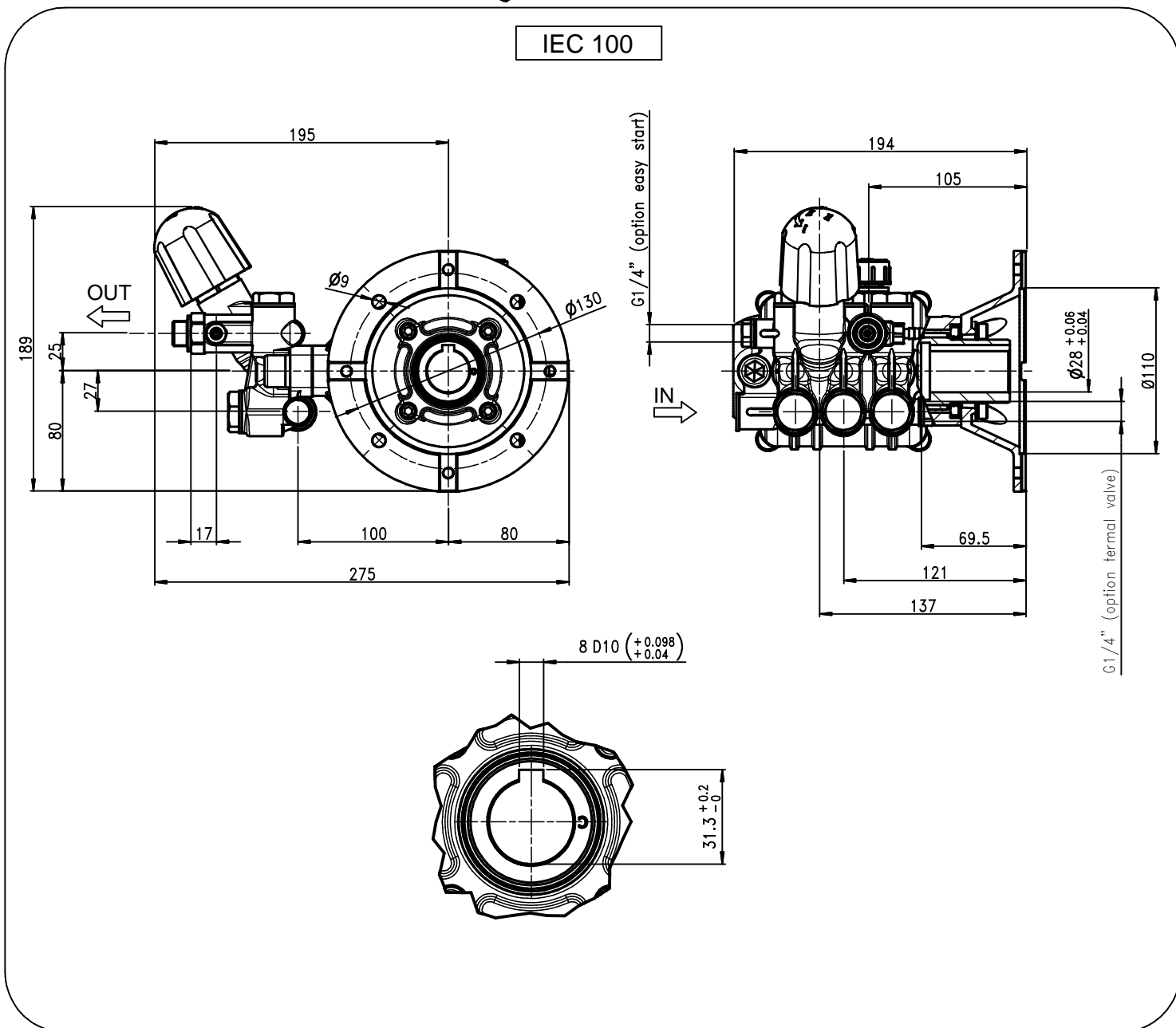

Lubrificazione: Olio SAE 10W-40
Capacità: 0.35Litri
Peso pompa: 5.5 Kg

Lubrication: SAE 10W-40 Oil
Capacity: 0.35Litres
Weight: 5.5 Kg

TMP IEC SERIES 2018

MAINTENANCE KIT / KIT MANUTENZIONE

KIT	Item Pos	Part Number Codice	Description	Descrizione	Q.TY Q.TÀ	TMP112C
A	3- 4- 5- 6- 7- 9 (45- 46- 47- 48- 49)- 10- 12- 13	9.853-583.0	KIT ORDINARY MAINTENANCE	KIT RIPARAZIONE ORDINARIA POMPA	1	•
B	(26- 27- 28- 29- 30- 31- 32- 33- 34- 35- 36- 37- 38- 39- 40- 42- 43- 44)	9.853-584.0	KIT ORDINARY VALVE MAINTENANCE	KIT RIPARAZIONE ORDINARIA VALVOLA	1	
C	19- 20- 21- 22	9.853-451.0	KIT POPPET MAINTENANCE	KIT RIPARAZIONE OTTURATORE VALVOLA	1	
F	9 (45- 46- 47- 48- 49)- 10	9.853-478.0	KIT COMPLETE CHECK VALVE	KIT RIPARAZIONE VALVOLE	1	
G	4- 5- 6- 7- 12- 13	9.853-585.0	KIT SEALS PACKING	KIT RIPARAZIONE GUARNIZIONI	1	

EXTRAORDINARY MAINTENANCE KIT / KIT MANUTENZIONE STRAORDINARIA

KIT	Item Pos	Part Number Codice	Description	Descrizione	Q.TY Q.TÀ	TMP112C
D	2	9.853-452.0	KIT PLUNGER OIL SEALS	KIT RIPARAZIONE ANELLI PARAOLIO	1	•
E	50- 51- 56- (60- 61- 62)- 63	9.853-587.0	KIT PLUNGER AND CONNECTING ROD MANINTENANCE	KIT RIPARAZIONE ASTA BIELLA	1	
H	63- 64- 65- 66	9.853-586.0	KIT PLUNGER	KIT PISTONE	3	

“Q.TY by Pump” => Necessary quantity to repair one pump
 “Q.TA’ per Pompa” => Quantità necessaria per riparare una pompa

IMPORTANT

IMPORTANTE

* Part available ONLY in kit
 Disponibile SOLO in kit

(...) Parts pre-assembled
 Parti pre-assemblate

PARTS LIST / LISTA PARTI

Item Pos	Part Number Codice	Description	Descrizione	KIT	Q.TY Q.TÀ	TMP112C
1	9.853-157.0	CRANKCASE	CARTER		1	
2*		PLUNGER OIL SEAL	ANELLO PARAOLIO	D	3	
3*		PRESSURE RING WASHER	RONDELLA PRESSORE	A-H	3	
4*		O-RING 2100 1,78X25,12	O-RING 2100 1,78x25,12	A-G-H	3	
5*		LP SEAL	GUARNIZIONE LP	A-G-H	3	
6*		INTERMED. RING	DIFFUSORE	A-G-H	3	
7*		HP SEAL	GUARNIZIONE HP	A-G-H	3	
8	9.853-188.0	MANIFOLD HOUSING	TESTATA		1	
9*		ASSEMBLY VALVE	PREMONTATO GABBIA VAM	A-F	6	
10*		O-RING 2100 1,78X25,12	O-RING 2100 1,78x25,12	A-F	6	
11	9.851-325.0	MANIFOLD PLUG	TAPPO VAM		6	
12*		SCREW M14X40	VITE TCEI M14X40	A-G-H	2	
13*		LOCK-WASHER	ROSETTA ELASTICA M14 DIN 7980	A-G-H	2	
14	9.853-160.0	INLET 3/4"FGH-3/8"M (optional)	INLET 3/4"FGH-3/8"M (opzionale)		1	
15	9.850-885.0	BALL SPRING	MOLLA SFERA		1	
16	9.851-251.0	BALL 7/32" (Ø5,55)	SFERA 7/32" (Ø5,55)		1	
17	9.850-698.0	O-RING 2018 - Ø1,78X4,48	O-RING 2018 - Ø1,78x4,48		1	
18	9.853-159.0	HOSE BARB	PORTAGOMMA		1	
19*		O-RING Ø2.4X4.6	OR METRICO Ø2.4x4.6	C	1	
20*		POPPET	OTTURATORE	C	1	
21*		POPPET SPRING	MOLLA OTTURATORE	C	1	
22*		O-RING 117 18,34X13,1 Ø2.62	OR 117 18,34x13,1 Ø2.62	C	2	
23	9.851-931.0	OUTLET	RACCORDO USCITA		1	
24	9.851-188.0	BONDED SEAL G3/8	BONDED SEAL G3/8		1	
25	9.853-161.0	QUICK BAL 3/8"F (optional)	QUICK BAL 3/8"F (opzionale)		1	
26*		O-RING 2050 15,98X12,42	O-RING 2050 15,98x12,42	B	1	
27*		VALVE SEAT	SEDE VALVOLA	B	1	
28*		POPPET VALVE	OTTURATORE VALVOLA	B	1	
29*		O-RING Ø1.78X14	O-RING Ø1.78x14	B	1	
30*		STEM NUT	BOCCOLA VALVOLA	B	1	
31*		O-RING 0200-20 24X20	O-RING 0200-20 24x20	B	1	
32*		CONNECTOR	RACCORDO DI GUIDA VALVOLA	B	1	
33*		SCREW M4X4 UNI5927	VITE STEI M4x4 UNI5927	B	1	
34*		NUT M28X1	DADO M28x1 VALVOLA	B	1	
35*		BACK RING OR024	ANTIESTRUSORE OR3024	B	1	
36*		O-RING 3024 11,26X6,02	O-RING 3024 11,26x6,02	B	2	
37*		BACK RING OR3024	ANTIESTRUSORE OR3024	B	1	
38*		PISTON	PISTONE VALVOLA	B	1	

Item Pos	Part Number Codice	DESCRIPTION	Description	KIT	Q.TY Q.TÀ	TMP112C
39*		PLATE	PIATTELLO MOLLA VALVOLA	B	1	
40*		SPRING	MOLLA VALVOLA	B	1	
42*		HANDLE	MANOPOLA OTTONE VALVOLA	B	1	
43*		ELASTIC PIN	SPINA ELASTICA 1,5x20 UNI 8752	B	1	
44*		HANDLE CAP	MANOPOLA VALVOLA	B	1	
45*		O-RING 2062 - Ø1,78X15,60	O-RING 2062 - Ø1,78x15,60	A-F	6	
46*		VALVE SEAT	SEDE VALVOLA	A-F	6	
47*		VALVE PLATE	PIATTELLO VAM	A-F	6	
48*		VALVE SPRING	MOLLA VAM	A-F	6	
49*		VALVE CAGE	GABBIA VAM	A-F	6	
50*		BEARING SEAL	COPERCHIO DI CHIUSURA Ø52x7	E	1	
51*		SEEGER Ø20 UNI7435	SEEGER ALB. Ø20 UNI7435	E	1	
52	9.850-461.0	ROLLER BEARING 6304	CUSCINETTO 6304-20x52x15		1	
53	9.853-163.0	OIL DIP STICK	TAPPO SFIATO OLIO G3/8		1	
54	9.853-187.0	CRANKSHAFT Ø28	ALBERO CAVO Ø28		1	
55	9.850-345.0	ROLLER BEARING NK45/20	CUSCINETTO NK45/20		1	
56*		PLUNGER OIL SEAL	ANELLO PARAOLIO Ø42x62x7	E	1	•
57	9.853-181.0	MOTOR FLANGE IEC100	FLANGIA MOTORE IEC100		1	
58	9.851-115.0	WASHER	ROSETTA M6 UNI 6592		4	
59	9.851-491.0	SCREW M6X20	VTCEI UNI 5931-M6x20		4	
60*		PLUNGER ROD	ASTA PISTONE	E	3	
61*		CONNECTING ROD PIN	SPINOTTO Ø9x24	E	3	
62*		CONNECTING ROD	BIELLA	E	3	
63*		SCREW M6x35	VITE M6x35	H-E	3	
64*		COPPER WASSER	ROSETTA RAME	H	3	
65*		CERAMIC PLUNGER	PISTONE CERAMICO	H	3	
66*		COPPER WASSER	ROSETTA RAME	H	3	
67		COVER SEAL	GUARNIZIONE COPERCHIO	E	1	
68	9.851-907.0	CRANKCASE COVER	COPERCHIO POSTERIORE		1	
69	9.850-805.0	SIGHT GLASS G 3/4"	SPIA LIVELLO OLIO G3/4		1	
70	9.851-474.0	SCREW M6X16	VTCEI UNI 5931-M6x16		4	
71	9.850-749.0	COPPER WASHER G1/4"	GUARNIZIONE RAME G1/4"		2	
72	9.851-305.0	BRASS PLUG G1/4	TAPPO OTTONE G1/4		2	