

Pump	Pressure		Volume		RPM	Required HP	Inlet port	Outlet port	Weight Kg
	bar	PSI	l/min	GPM					
NPM1125GR	250	3625	11.5	3.0	3400	7.2	G 1/2	G 3/8	10.5
NPM1325GR	250	3625	13.5	3.5	3400	8.5	G 1/2	G 3/8	10.5
NPM1425GR	250	3625	14.5	3.8	3400	9.3	G 1/2	G 3/8	10.5
NPM1725GR	250	3625	17.0	4.4	3400	10.7	G 1/2	G 3/8	10.5

Dimensioni d'ingombro

Overall dimensions (mm)

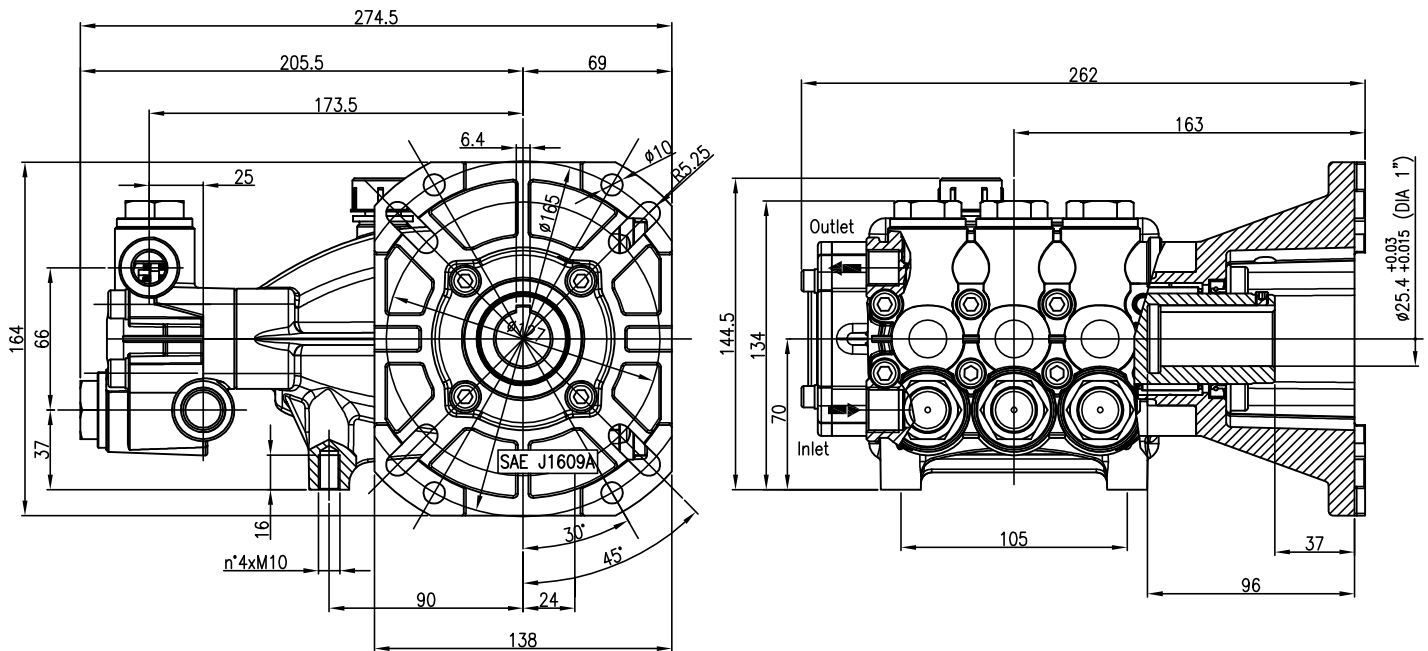

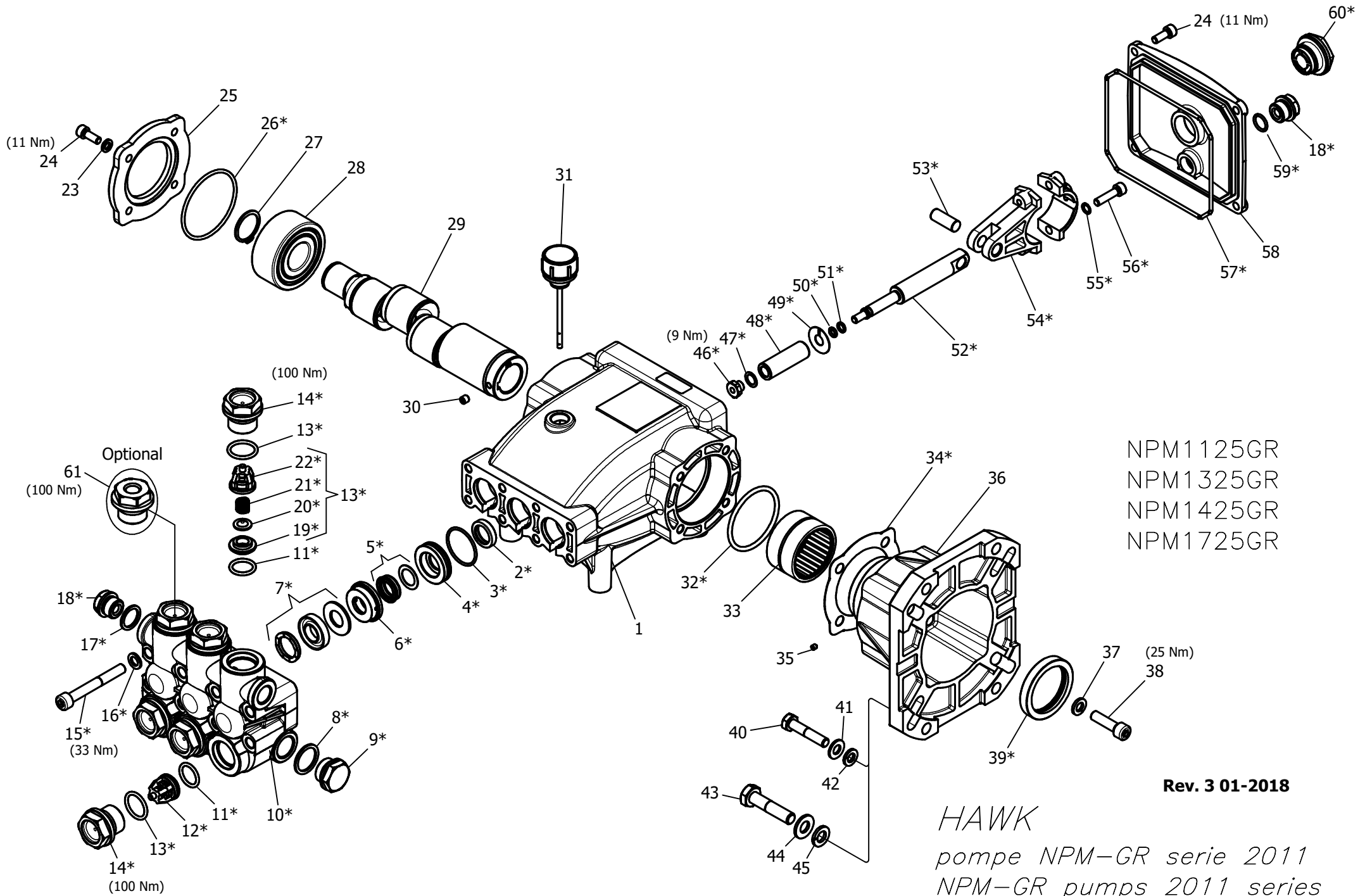

NPM-GR 2011 SERIES

ORDINARY MAINTENANCE KIT / KIT MANUTENZIONE ORDINARIA

KIT	Item Pos.	Part Number Codice	Description	Descrizione	Q.TY by Pump Q.TA per Pompa	NPM1125GR	NPM1325GR	NPM1425GR	NPM1725GR
A	3- 5- 7	1.099-835.0	PLUNGER SEALS DIA. 15 mm	GUARNIZIONI PISTONE Ø15	1				
B	11- 12- 13 (19- 20- 21 22)	1.905-543.0	COMPLETE VALVE	VALVOLA COMPLETA	1	•	•	•	•

EXTRAORDINARY MAINTENANCE KIT / KIT MANUTENZIONE STRAORDINARIA

KIT	Item Pos.	Part Number Codice	Description	Descrizione	Q.TY by Pump Q.TA per Pompa	NPM1125GR	NPM1325GR	NPM1425GR	NPM1725GR
C	3- 4- 5- 6- 7	1.905-653.0	COMPLETE SEALS PACKING DIA. 15 mm	PACCO COMPLETO GUARNIZIONI PISTONE Ø15	1				
D	46- 47- 48 49- 50- 51	1.099-837.0	PLUNGER DIA. 15 mm	PISTONE Ø15	3				
E	2	1.099-751.0	PLUNGER OIL SEALS	ANELLI TENUTA OLIO ASTA	1				
F	18- 26- 32 34- 39- 57 59- 60	1.905-654.0	KIT CRANKCASE SEALS	KIT TENUTE CARTER	1				
G	3- 4- 5- 6- 7 8- 9- 10- 11 12- 13- 14 15- 16- 17 18 (19- 20 21- 22)	1.099-838.0	COMPLETE MANIFOLD	TESTATA COMPLETA	1	•	•	•	•
H	46- 47- 50 51- 52- 53 54- 55- 56	1.905-544.0	CONNECTING ROD PLUNGER ROD ASSY	PREMONTATO ASTA-BIELLA PISTONE	3				
I	13- 14	1.904-251.0	VALVE PLUG ASSY	PREMONTATO TAPPO VAM	6				

“Q.TY by Pump” => Necessary quantity to repair one pump
 “Q.TA’ per Pompa” => Quantità necessaria per riparare una pompa

OPTIONAL

Item Pos.	Part Number Codice	Description	Descrizione	Q.TY by Pump Q.TA per Pompa	NPM1125GR	NPM1325GR	NPM1425GR	NPM1725GR
51	9.853-426.0	THREADED BRASS PLUG G1/4	PREMONTATO TAPPO FORATO	1	•	•	•	•

TOOL KIT

Part Number Codice	Description	Descrizione	Q.TY by Pump Q.TA per Pompa	NPM1125GR	NPM1325GR	NPM1425GR	NPM1725GR
1.099-667.0	TOOL-KIT	TOOL-KIT	1	•	•	•	•
1.904-414.0	OIL SEAL EXTRACTOR TOOL-KIT	TOOL-KIT ESTRAZIONE PARAOLIO	1	•	•	•	•

IMPORTANT

IMPORTANTE

* Part available **ONLY** in kit
Disponibile **SOLO** in kit

(...) Parts pre-assembled
Parti pre-assemblate

PARTS LIST LISTA PARTI

Item Pos	Part Number Codice	Description	Descrizione	KIT	Q.TY Q.TA	NPM1125GR	NPM1325GR	NPM1425GR	NPM1725GR
1	9.850-376.0	CRANKCASE	CARTER		1				
2*		PLUNGER OIL SEAL	ANELLO RADIALE	E	3				
3*		"O" RING Ø1.78X31.47	"O" RING Ø1.78X31.47	A-C-G	3				
4*		PRESSURE RING 15 MM	PRESSORE "U" Ø15	C-G	3				
5*		LOW PRESSURE "U" SEAL, DIA.15 MM	ANELLO TENUTA "U" Ø15	A-C-G	3				
6*		INTERMED. RING 15 MM	DIFFUSORE INTER. Ø15	C-G	3				
7*		HIGH PRESSURE "U" SEAL, DIA.15 MM	ANELLO TENUTA "U" Ø15	A-C-G	3				
8*		COPPER WASHER G1/2	GUARNIZIONE RAME	G	1				
9*		PLUG G1/2	TAPPO G1/2	G	1				
10*		MANIFOLD HOUSING	TESTATA	G	1				
11*		"O" RING Ø2.62X17.13	"O" RING Ø2.62X17.13	B-G	6				
12*		VALVE ASSEMBLY	VALVOLA PREMONTATA	B-G	6				
13*		"O" RING Ø2.62X20.29	"O" RING Ø2.62X20.29	B-G-I	6				
14*		VALVE PLUG	TAPPO VALVOLA	G-I	6				
15*		MANIFOLD STUD BOLT M8X65 GEOMET	VITE M8X65 GEOMET	G	8	•	•	•	•
16*		WASHER Ø8,5	ROSETTA Ø8.5	G	16				
17*		COPPER WASHER G3/8	GUARNIZIONE RAME	G	1				
18*		PLUG G3/8	TAPPO G3/8	G-F	2				
19*		VALVE SEAT	SEDE VALVOLA	B-G	6				
20*		VALVE PLATE	PIATTELLO VALVOLA	B-G	6				
21*		VALVE SPRING	MOLLA VALVOLA	B-G	6				
22*		VALVE CAGE	GABBIA VALVOLA	B-G	6				
23	9.851-115.0	WASHER Ø6.4/12.5X1.6	ROSETTA Ø6.4/12.5X1.6		4				
24	9.851-474.0	HEXAGONAL SCREW TCEI M6X16	VITE TCEI M6X16		8				
25	9.850-622.0	CLOSED BEARING FLANGE	FLANGIA CHIUSA		1				
26*		"O" RING Ø2.62X61.6	"O" RING Ø2.62X61.6	F	1				
27	9.851-198.0	SNAP RING	ANELLO Ø25		1				
28	9.850-464.0	DOUBLE ROW BALL BEARING	CUSCINETTO DOPPIA CORONA		1				
29	9.850-155.0	HOLLOW SHAFT	ALBERO CAVO		1	•			
	9.850-156.0	" "	" "		1		•		
	9.850-157.0	" "	" "		1			•	
	9.850-158.0	" "	" "		1				•
30	9.851-520.0	SET SCREW STEI M6X6	VITE STEI M6X6		1				
31	9.851-286.0	OIL DIP STICK	TAPPO LIVELLO OLIO		1				
32*		"O" RING Ø3.53X55.56	"O" RING Ø3.53X55.56	F	1				
33	9.850-351.0	NEEDLE ROLLER BEARING	CUSCINETTO A RULLINI		1	•	•	•	•
34	9.850-652.0	ENGINE FLANGE GASKET	GUARNIZIONE FLANGIA MOTORE		1				
35	9.851-521.0	SET SCREW STEI M4X5	VITE STEI M4X5		1				
36	9.850-621.0	ENGINE FLANGE	FLANGIA MOTORE		1				

Item Pos	Part Number Codice	Description	Descrizione	KIT	Q.TY Q.TA	NPM1125GR	NPM1325GR	NPM1425GR	NPM1725GR
37	9.851-157.0	SPRING WASHER Ø8.1/12.7X2	ROSETTA ELASTICA Ø8.1/12.7X2		4				
38	9.851-482.0	FLANGE SCREW TCEI M8X30	VITE TCEI M8X30		4				
39	9.850-008.0	CRANKSHAFT SEAL	ANELLO RADIALE		1				
40	9.851-509.0	ENGINE SCREW 5/16"	VITE 5/16"		4				
41	9.851-131.0	WASHER Ø8.2/20X1.5	ROSETTA Ø8.2/20X1.5		4				
42	9.851-152.0	SPRING WASHER Ø8	ROSETTA SCHNORR Ø8		4				
43	9.851-510.0	ENGINE SCREW 3/8"	VITE 3/8"		4				
44	9.851-132.0	WASHER Ø10/18X2	ROSETTA Ø10/18X2		4				
45	9.850-839.0	SPRING WASHER Ø10	ROSETTA ELASTICA Ø10		4				
46*		PLUNGER NUT M6	DADO PISTONE M6	D-H	3				
47*		WASHER Ø9,2/13,5X0,5	ROSETTA Ø9,2/13,5X0,5	D-H	3				
48*		PLUNGER 15MM	PISTONE Ø15	D	3				
49*		COPPER SPACER Ø9.3/24X0.5	ROSETTA RAME Ø9.3/24X0.5	D	3				
50*		"O" RING Ø1.78X5.28	"O" RING Ø1.78X5.28	D-H	3				
51*		TEFLON RING	ANELLO ANTIESTRUSIONE	D-H	3				
52*		PLUNGER ROD	ASTA PISTONE	H	3				
53*		CONNECTING ROD PIN	SPINOTTO	H	3				
54*		CONNECTING ROD	BIELLA	H	3				
55*		SPRING WASHER Ø6	ROSETTA ELASTICA Ø6	H	6				
56*		CONNECTING ROD SCREW M6X30	VITE M6X30	H	6				
57*		"O" RING Ø 2.62X126.67	"O" RING Ø 2.62X126.67	F	1				
58	9.850-388.0	CRANKCASE COVER	COPERCHIO POSTERIORE		1				
59		"O" RING Ø1.78X14	"O" RING Ø1.78X14	F	1				
60		SIGHT GLASS, G3/4	SPIA LIVELLO OLIO G3/4	F	1				