

Pump Pompe Pumpen Pompa	Pressure Pression Druck Pressione		Volume Débit Wassermenge Portata		RPM tours/min u.p.m. giri/min	Power Puissance Leistung Potenza		Inlet port Entrée Eingang Aspirazione	Outlet Sortie Ausgang Mandata	Weight Kg Poids Kg Gewicht Kg Peso Kg
	bar	PSI	l/min	GPM		HP	kW			
HHP2750	500	7250	27	7.1	1450	35.5	26.1	G 3/4	G 1/2	51
HHP3650	500	7250	36	9.5	1450	46.9	34.5	G 3/4	G 1/2	51
HHP4150	500	7250	41	10.8	1450	53.7	39.5	G 3/4	G 1/2	51
HHP5040	400	5800	50	13.3	1740	51.5	37.9	G 3/4	G 1/2	51

Dimensioni d'ingombro

Overall dimensions

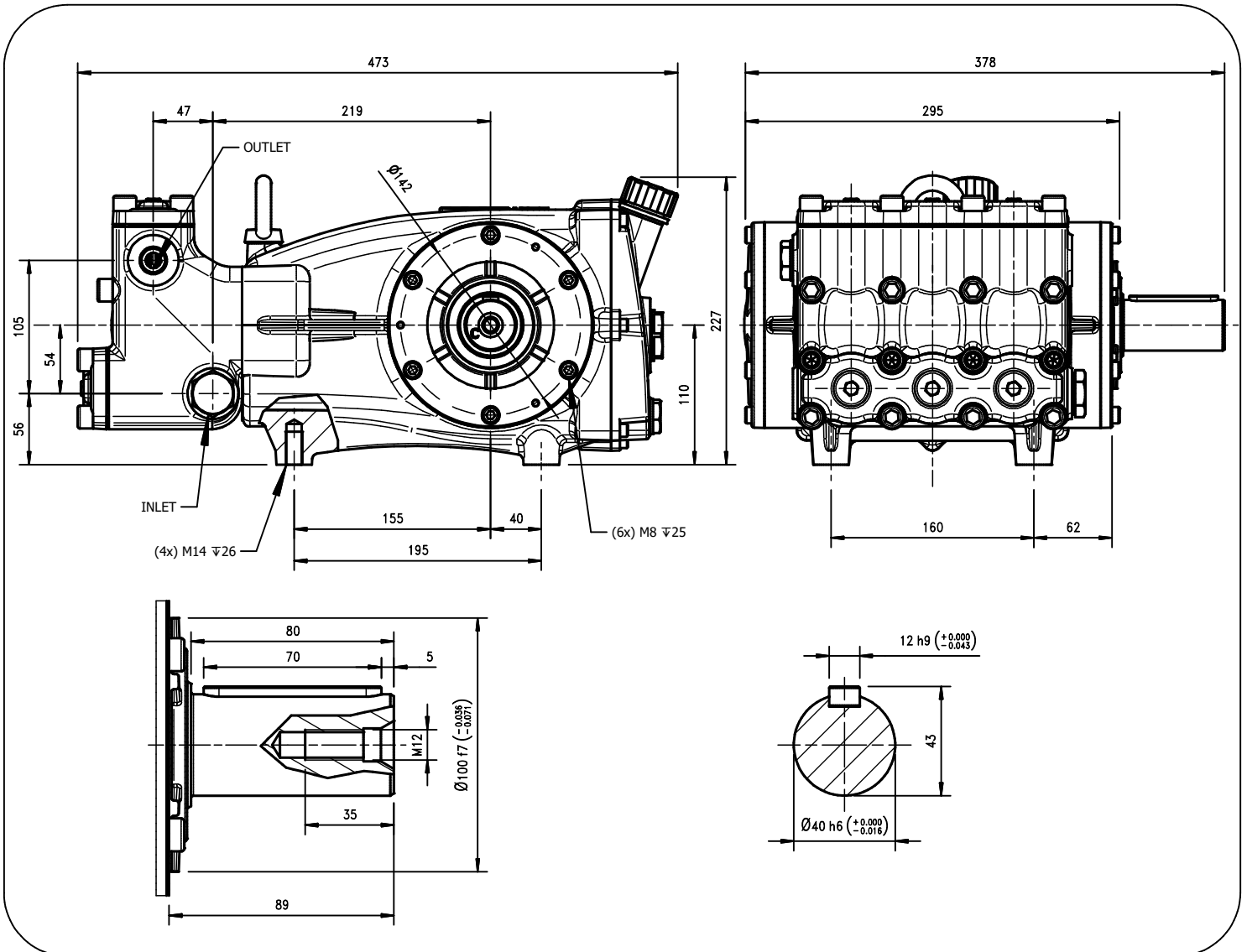

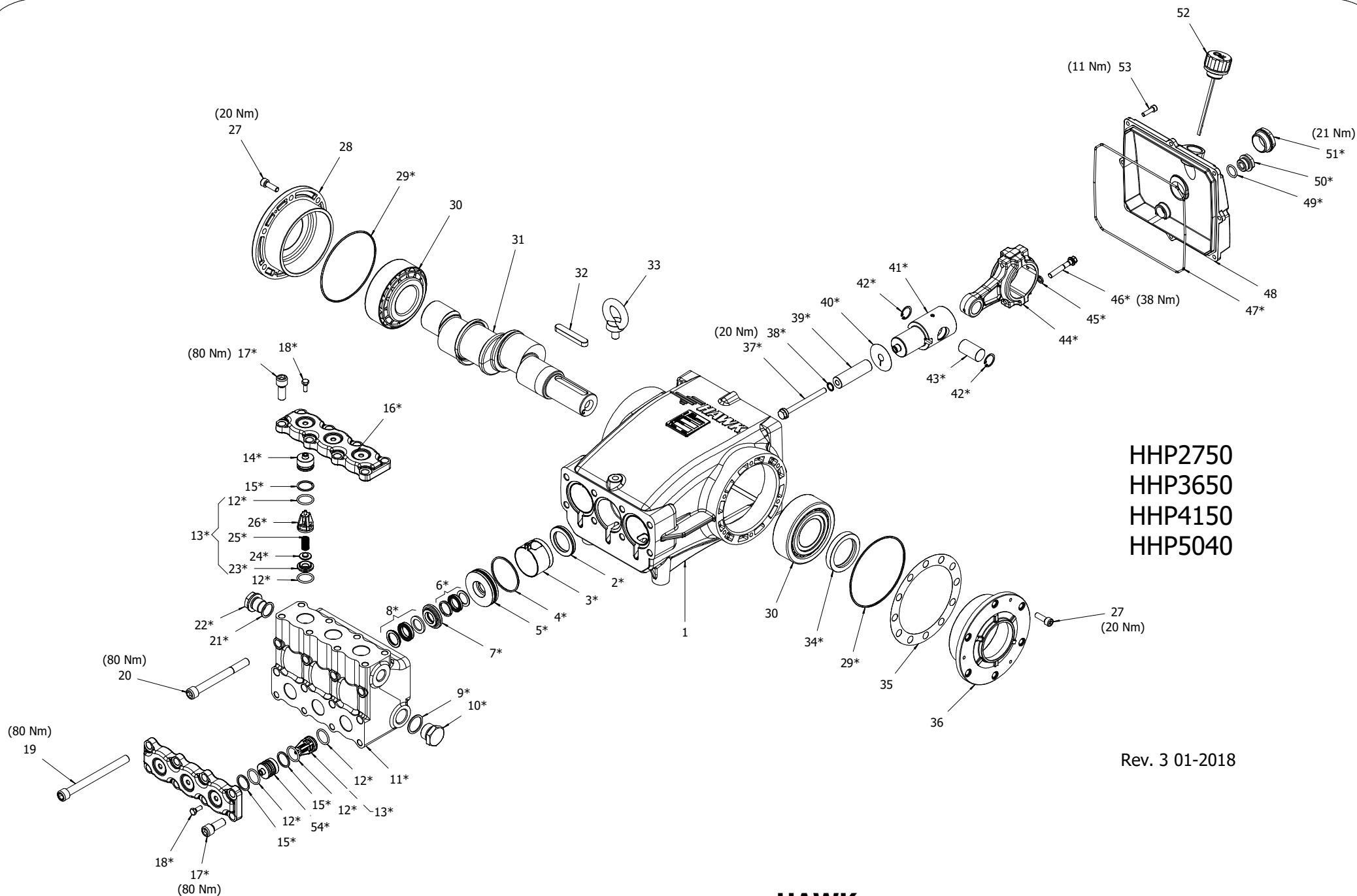

HHP2750
HHP3650
HHP4150
HHP5040

Rev. 3 01-2018

HAWK
Pompe HHP 1450 rpm serie 2011
HHP pumps 1450 rpm 2011 series

HHP 1450 RPM 2013 SERIES

ORDINARY MAINTENANCE KIT / KIT MANUTENZIONE ORDINARIA

KIT	Item Pos.	Part Number Codice	Description	Descrizione	Q.TY by Pump Q.TA per Pompa	HHP2750R/L	HHP3650R/L	HHP4150R/L	HHP5040R/L
A	4- 6- 8	1.099-821.0	PLUNGER SEALS DIA. 20 mm	GUARNIZIONI PISTONE Ø20	1	•	•	•	•
B	12- 13 (23- 24 25- 26) 15	1.905-710.0	COMPLETE VALVE	VALVOLA COMPLETA	1				

EXTRAORDINARY MAINTENANCE KIT / KIT MANUTENZIONE STRAORDINARIA

KIT	Item Pos.	Part Number Codice	Description	Descrizione	Q.TY by Pump Q.TA per Pompa	HHP2750R/L	HHP3650R/L	HHP4150R/L	HHP5040R/L
C	4- 5- 6- 7- 8	1.905-711.0	COMPLETE SEALS PACKING DIA. 20 mm	PACCO COMPLETO GUARNIZIONI PISTONE Ø20	1				
D	37- 38- 39- 40	1.099-824.0	PLUNGER DIA. 20 mm	PISTONE Ø20	3				
E	3x (2- 3)	1.099-817.0	PLUNGER OIL SEALS	ANELLI TENUTA OLIO ASTA	1				
F	29- 34- 47- 49- 50 51	1.905-706.0	KIT CRANKCASE SEALS	KIT TENUTE CARTER	1	•	•	•	•
G	4- 5- 6- 7- 8- 9- 10 11- 12- 13 (23- 24 25- 26) 14- 15- 16 17- 18- 21- 22- 54	1.099-830.0	COMPLETE MANIFOLD	TESTATA COMPLETA	1				
H	37- 38- 40- 41- 42 43- 44- 45- 46	1.905-707.0	CONNECTING ROD PLUNGER ROD ASSY	PREMONTATO ASTA-BIELLA PISTONE	3				

“Q.TY by Pump” => Necessary quantity to repair one pump
 “Q.TA’ per Pompa” => Quantità necessaria per riparare una pompa

TOOL KIT

<i>Part Number Codice</i>	<i>Description</i>	<i>Descrizione</i>	<i>Q.TY by Pump Q.TA per Pompa</i>	<i>HHP2750R/L</i>	<i>HHP3650R/L</i>	<i>HHP4150R/L</i>	<i>HHP5040R/L</i>
1.099-665.0	TOOL-KIT	TOOL-KIT	1	•	•	•	•



IMPORTANT

IMPORTANTE

*	Part available ONLY in kit Disponibile SOLO in kit
----------	---

(...) **Parts pre-assembled
Parti pre-assemblate**

PARTS LIST LISTA PARTI

Item Pos	Part Number Codice	Description	Descrizione	KIT	Q.TY Q.TÀ	HHP2750R/L	HHP3650R/L	HHP4150R/L	HHP5040R/L
1	9.851-902.0	CRANKCASE	CARTER		1				
2*		PLUNGER OIL SEAL	ANELLO RADIALE	E	3				
3*		PLASTIC BUSHING	BOCCOLA CORTECO ASTE	E	3				
4*		"O" RING Ø2.62X56,82	"O" RING Ø2.62X56,82	A-C-G	3				
5*		PRESSURE RING 20 MM	PRESSORE "U" Ø20	C-G	3				
6*		"U" SEAL, Ø20X28 MM	ANELLO TENUTA "U" Ø20x28	A-C-G	3				
7*		INTERMED. RING 20MM	DIFFUSORE INTER. Ø20	C-G	3				
8*		"U" SEAL, Ø20X30 MM	ANELLO TENUTA "U" Ø20x30	A-C-G	3				
9*		COPPER WASHER	GUARNIZIONE RAME G 3/4	G	1				
10*		STAINLESS STEEL PLUG G 3/4	TAPPO G ¾ INOX	G	1				
11*		MANIFOLD HOUSING	TESTATA	G	1				
12*		"O" RING Ø2.62X22,22	"O" RING Ø2.62X22,22	B-G	6				
13*		VALVE ASSEMBLY	VALVOLA PREMONTATA	B-G	6				
14*		VALVE PLUG	TAPPO VALVOLA	G	6				
15*		BACK RING	ANELLO ANTIESTRUSIONE	G	3				
16*		VALVES COVER	COPERCHIO VAM	G	2	•	•	•	•
17*		VALVE COVER SCREW	VITE TCEI M12X30 UNI 5931	G	12				
18*		VALVE PLUG SCREW	VITE TE M6X16 UNI 5739	G	6				
19	9.851-471.0	MANIFOLD STUD BOLT	VITE TCEI M12X140 UNI 5931		4				
20	9.851-472.0	MANIFOLD STUD BOLT	VITE TCEI M12X120 UNI 5931		4				
21*		COPPER WASHER	GUARNIZIONE RAME G 1/2	G	4				
22*		STAINLESS STEEL PLUG G1/2	TAPPO G1/2 INOX	G	1				
23*		VALVE SEAT	SEDE VALVOLA	B-G	6				
24*		VALVE PLATE	PIATTELLO VALVOLA	B-G	6				
25*		VALVE SPRING	MOLLA VALVOLA	B-G	6				
26*		VALVE CAGE	GABBIA VALVOLA	B-G	6				
27	9.851-468.0	BEARING HOUSING SCREW	VITE TCEI M8X25 UNI 5931		12				
28	9.850-646.0	CLOSED BEARING SCREW	FLANGIA CHIUSA		1				
29*		"O" RING Ø2.62X120.32	"O" RING Ø2.62X120.32	F	2				
30	9.850-353.0	ROLLER BEARING	CUSCINETTO 32310 RULLI CONICI		2				
31	9.850-184.0	SINGLE-ENDED CRANCKSHAFT	ALBERO SINGOLA P.D.F		1	•			
	9.850-185.0	" " " "	" " " "		1		•		
	9.850-186.0	" " " "	" " " "		1			•	•
32	9.850-449.0	CRANKSHAFT KET	CHIAVETTA		1				
33	9.851-454.0	EYEBOLT	GOLFARE M12		1				
34*		CRANKSHAFT SEAL	ANELLO RADIALE	F	1	•	•	•	•
35	9.850-549.0	SHIM	DISTANZIALE		1				
36	9.850-645.0	BEARING HOUSING	FLANGIA APERTA		1				
37*		PLUNGER BOLT	VITE PISTONE	D-H	3				

Item Pos	Part Number Codice	Description	Descrizione	KIT	Q.TY Q.TÀ	HHP2750R/L	HHP3650R/L	HHP4150R/L	HHP5040R/L
38*		"O" RING Ø1.78X11.11	"O" RING Ø1.78X11.11	D-H	3				
39*		PLUNGER DIA. 20	PISTONE Ø20	D	3				
40*		COPPER SPACER	ROSETTA RAME PISTONE	D	3				
41*		PLUNGER ROD	ASTA PISTONE	H	3				
42*		SNAP RING	ANELLO Ø22	H	6				
43*		CONNECTING ROD PIN	SPINOTTO	H	3				
44*		CONNECTING ROD	BIELLA	H	3				
45*		SPRING WASHER	ROSETTA ELASTICA Ø8	H	6				
46*		CONNECTING ROD SCREW	VITE BIELLA	H	6	•	•	•	•
47*		"O" RING Ø2.62X209.23	"O" RING Ø2.62X209.23	F	1				
48	9.850-386.0	CRANKCASE COVER	COPERCHIO CARTER		1				
49*		"O" RING Ø2.62X17.13	"O" RING Ø2.62X17.13	F	1				
50*		BRASS PLUG G 1/2	TAPPO OTTONE G 1/2	F	1				
51*		SIGHT GLASS, G 1"	SPIA LIVELLO OLIO G1"	F	1				
52*		OIL DIP STICK G 3/4	TAPPO SFIATO OLIO G 3/4	F	1				
53	9.851-480.0	COVER SCREW	VITE COPERCHIO		5				
54*		VALVE PLUG	TAPPO VALVOLA	G	3				