

XXTI

Caratteristiche Tecniche

Albero maschio – Solid shaft

Technical Characteristics

Pump Pompa	Pressure Pressione		Volume Portata				RPM giri/min		Power Potenza			
			l/min		GPM				HP		kW	
	bar	PSI	50 Hz	60 Hz	50 Hz	60 Hz	50 Hz	60 Hz	50 Hz	60 Hz	50 Hz	60 Hz
XXT4121I	210	3045	41	49	10.8	12.9	1450	1740	22.1	26.4	16.2	19.4
XXT5520I	200	2900	55	66	14.6	17.5	1450	1740	28.8	34.6	21.2	25.4
XXT7015I	150	2175	70	84	18.5	22.2	1450	1740	28.8	34.6	21.2	25.4

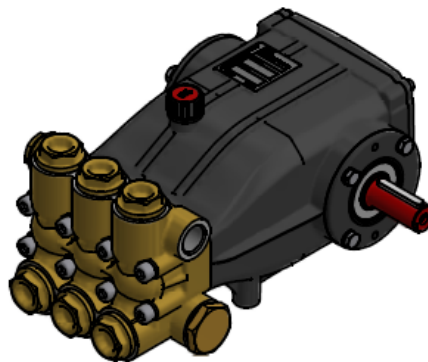

Dimensioni d'ingombro

Overall dimensions

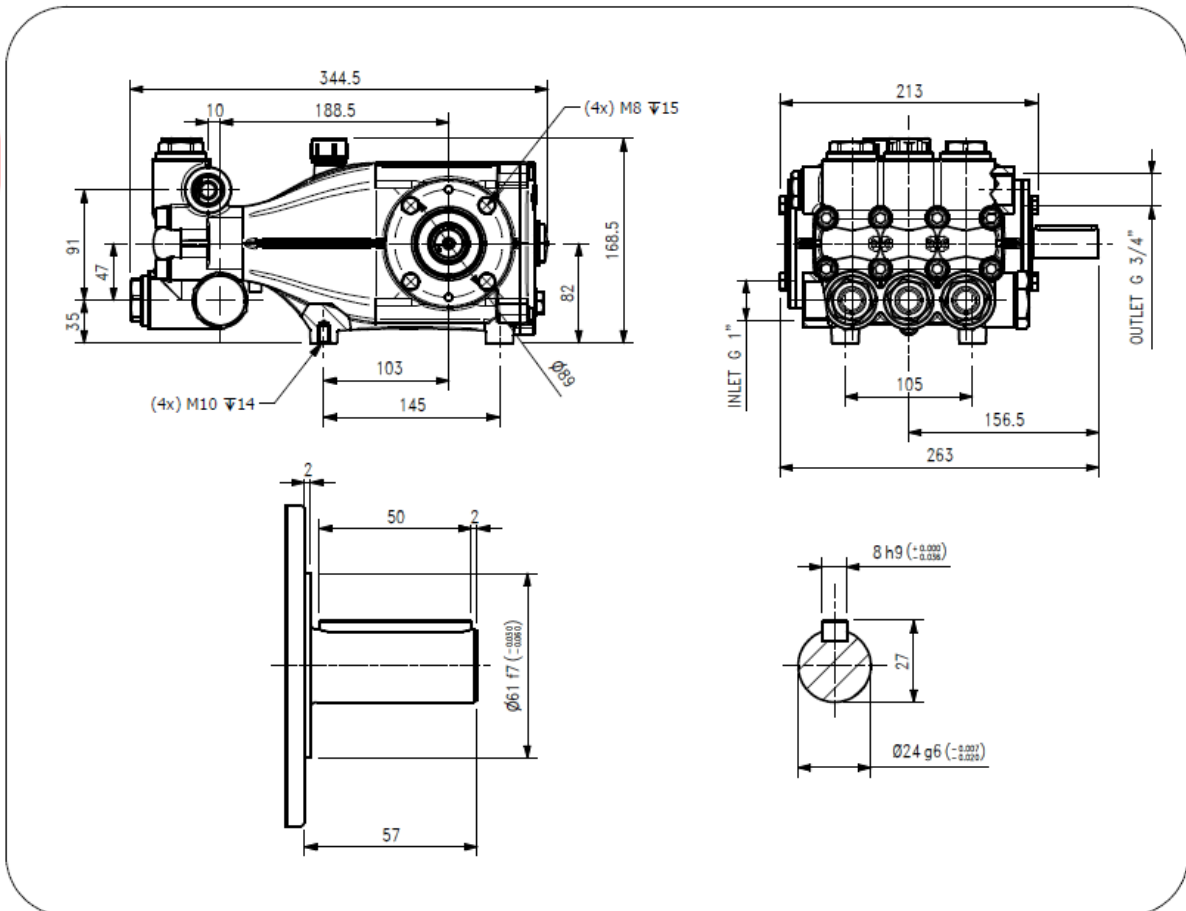

Lubrificazione: Olio SAE 10W40
 Capacità: 1.2 Litri
 Peso pompa: 18.6 kg

Lubrication: SAE 10W40 Oil
 Capacity: 1.2 Litres
 Weight: 18.6 kg

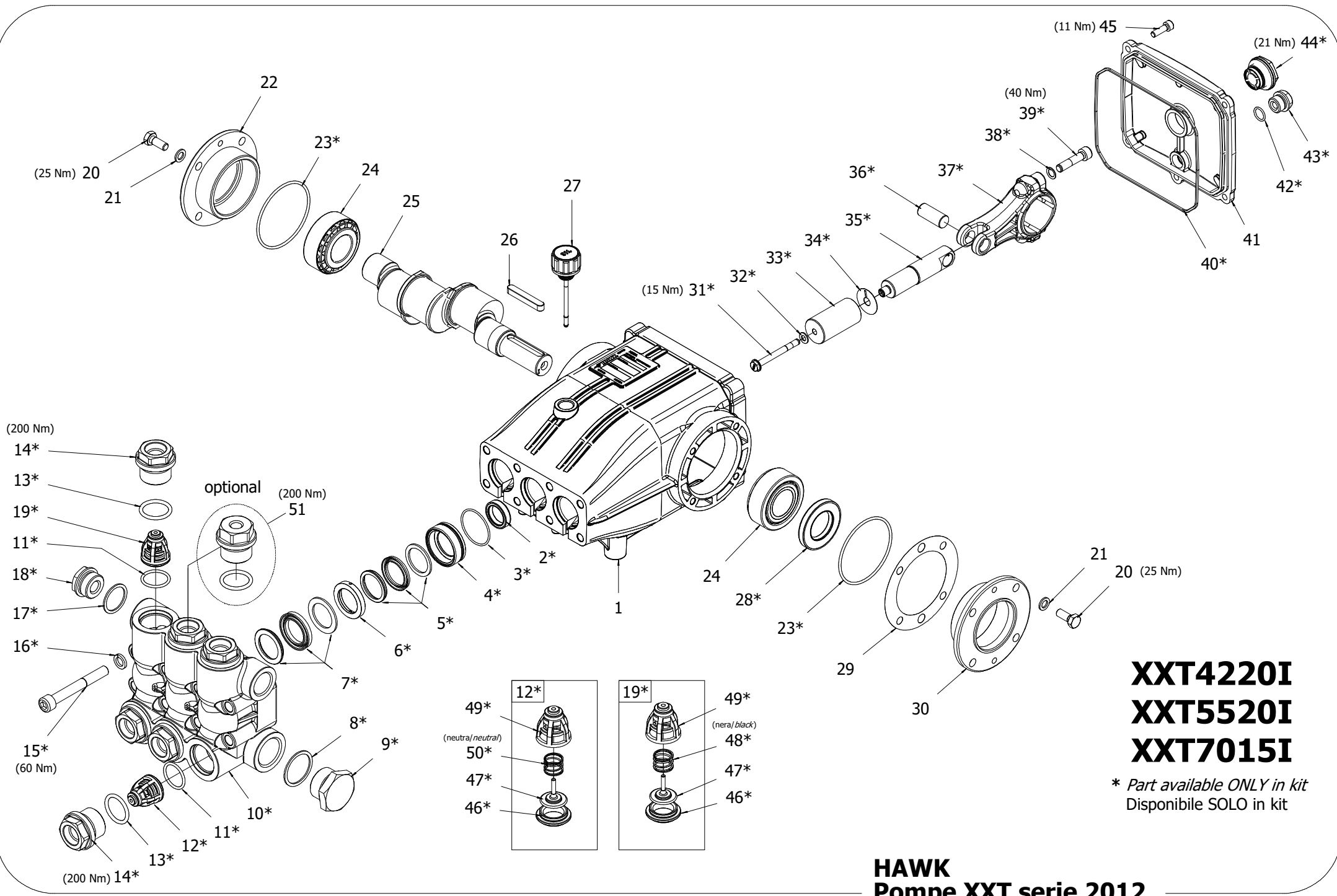

XXT4220I
XXT5520I
XXT7015I

* Part available ONLY in kit
 Disponibile SOLO in kit

HAWK
Pompe XXT serie 2012
XXT pumps 2012 series

XXT 2012 SERIES

ORDINARY MAINTENANCE KIT / KIT MANUTENZIONE ORDINARIA

KIT	Item Pos.	Part Number Codice	Description	Descrizione	Q.TY by Pump Q.TA per Pompa	XXT7015I	XXT5520I	XXT4121I
A	3- 5- 7	1.099-770.0	PLUNGER SEALS DIA. 25 mm	GUARNIZIONI PISTONE Ø25	1		•	•
		1.099-771.0	PLUNGER SEALS DIA. 28 mm	GUARNIZIONI PISTONE Ø28		•		
B	11- 12 (46-47- 50- 49)- 13- 19 (46-47-48-49)	1.905-594.0	COMPLETE VALVE	VALVOLA COMPLETA	1	•	•	•

EXTRAORDINARY MAINTENANCE KIT / KIT MANUTENZIONE STRAORDINARIA

KIT	Item Pos.	Part Number Codice	Description	Descrizione	Q.TY by Pump Q.TA per Pompa	XXT7015I	XXT5520I	XXT4121I
C	3- 4- 5- 6- 7	1.905-853.0	COMPLETE SEALS PACKING DIA. 25 mm	PACCO COMPLETO GUARNIZIONI PISTONE Ø25	1		•	•
		1.905-854.0	COMPLETE SEALS PACKING DIA. 28 mm	PACCO COMPLETO GUARNIZIONI PISTONE Ø28		•		
D	31- 32- 33- 34	1.099-777.0	PLUNGER DIA. 25 mm	PISTONE Ø25	3		•	•
		1.099-778.0	PLUNGER DIA. 28 mm	PISTONE Ø28		•		
E	2	1.099-766.0	PLUNGER OIL SEALS	ANELLI TENUTA OLIO ASTA	1	•	•	•
F	23- 28- 40- 42- 43- 44	1.905-613.0	KIT CRANKCASE SEALS	KIT TENUTE CARTER	1	•	•	•
G	3- 4- 5- 6- 7 8- 9- 10- 11 12 (46- 47- 50- 49)- 13- 14 15- 16- 17 18- 19 (46- 47-48-49)	1.099-790.0	COMPLETE MANIFOLD 25	TESTATA COMPLETA Ø25	1		•	•
		1.099-791.0	COMPLETE MANIFOLD 28	TESTATA COMPLETA Ø28		•		
H	31- 32- 35- 36- 37- 38- 39	1.904-182.0	CONNECTING ROD PLUNGER ROD ASSY	PREMONTATO ASTA-BIELLA PISTONE	3	•	•	•
I	13- 14	1.904-326.0	VALVE PLUG ASSY	PREMONTATO TAPPO VAM	6	•	•	•

“Q.TY by Pump” => Necessary quantity to repair one pump
 “Q.TA’ per Pompa” => Quantità necessaria per riparare una pompa

OPTIONAL

Item Pos.	Part Number Codice	Description	Descrizione	Q.TY by Pump Q.TA per Pompa	XXT7015I	XXT5520I	XXT4121I
51	9.853-430.0	THREADED BRASS PLUG G1/4	PREMONTATO TAPPO FORATO	1	•	•	•

TOOL KIT

Part Number Codice	Description	Descrizione	Q.TY by Pump Q.TA per Pompa	XXT7015I	XXT5520I	XXT4121I
1.099-665.0	TOOL-KIT	TOOL-KIT	1	•	•	•
1.905-659.0	OIL SEAL EXTRACTOR TOOL-KIT	TOOL-KIT ESTR. PARAOLIO	1	•	•	•

IMPORTANT

IMPORTANTE

* Part available **ONLY** in kit
Disponibile **SOLO** in kit

(...) Parts pre-assembled
Parti pre-assemblate

PARTS LIST LISTA PARTI

Item Pos	Part Number Codice	Description	Descrizione	KIT	Q.TY Q.TA	XXT7015I	XXT5520I	XXT4121I
1	9.850-377.0	CRANKCASE	CARTER		1			
2*		PLUNGER OIL SEAL	ANELLO RADIALE	E	3	•	•	•
3*		"O" RING Ø1.78X37.82	"O" RING Ø1.78X37.82	A-C-G	3			
4*		PRESSURE RING 25MM	PRESSORE "U" Ø25	C-G	3		•	•
		PRESSURE RING 28MM	PRESSORE "U" Ø28			•		
5*		LOW PRESSURE "U" SEAL, DIA.25MM	ANELLO TENUTA "U" Ø25	A-C-G	3		•	•
		LOW PRESSURE "U" SEAL, DIA.28MM	ANELLO TENUTA "U" Ø28			•		
6*		INTERMED. RING 25MM	DIFFUSORE INTER. Ø25	C-G	3		•	•
		INTERMED. RING 28MM	DIFFUSORE INTER. Ø28			•		
7*		HIGH PRESSURE "U" SEAL, DIA.25MM	ANELLO TENUTA "U" Ø25	A-C-G	3		•	•
		HIGH PRESSURE "U" SEAL, DIA.28MM	ANELLO TENUTA "U" Ø28			•		
8*		COPPER WASHER G1"	GUARNIZIONE RAME G1"	G	1			
9*		PLUG G1"	TAPPO G1"	G	1			
10*		MANIFOLD HOUSING 28/25	TESTATA Ø28/25	G	1			
11*		"O" RING Ø2.62X25.07	"O" RING Ø2.62X25.07	B-G	6			
12*		INLET VALVE	VALVOLA ASPIRAZIONE	B-G	6			
13*		"O" RING Ø2.62X26.58	"O" RING Ø2.62X26.58	B-G-I	6			
14*		VALVE PLUG	TAPPO VALVOLA	G-I	6			
15*		MANIFOLD SCREW M10X80 GEOMET	VITE M10X80 GEOMET	G	8			
16*		WASHER Ø10.2	ROSETTA Ø10.2	G	16	•	•	•
17*		COPPER WASHER G3/4	GUARNIZIONE RAME G3/4	G	1			
18*		PLUG G3/4	TAPPO G3/4	G-F	2			
19*		OUTLET VALVE	VALVOLA MANDATA	B-G	6			
20	9.851-503.0	HEXAGONAL SCREW M8X20	VITE M8X20		8			
21	9.851-114.0	WASHER Ø 8,5	ROSETTA PIANA Ø8,5		8			
22	9.850-624.0	CLOSED BEARING HOUSING	FLANGIA CHIUSA		1			
23*		"O" RING Ø1.78X71.12	"O" RING Ø1.78X71.12	F	2			
24	9.850-348.0	ROLLER BEARING	CUSCINETTO A RULLI		2			
25	9.850-195.0	CRANKSHAFT Ø24	ALBERO ECCENTRICO Ø24		1	•	•	
	9.850-193.0	"	"					•
26	9.850-447.0	CRANKSHAFT KEY	CHIAVETTA		1			
27	9.851-287.0	OIL DIP STICK	TAPPO LIVELLO OLIO		1			
28*		CRANKSHAFT SEAL	ANELLO RADIALE	F	1	•	•	•
29	9.850-546.0	SHIM	DISTANZIALE		1			
30	9.850-597.0	BEARING HOUSING	FLANGIA		1			
31*		PLUNGER SCEW	VITE PISTONE	D-H	3			

Item Pos	Part Number Codice	Description	Descrizione	KIT	Q.TY Q.TÀ	XXT7015I	XXT5520I	XXT4121I
32*		COPPER SPACER Ø 11.2/15X0.5	ROSETTA RAME Ø 1.2/15X0.5	D-H	3	•	•	•
33*		PLUNGER 25MM	PISTONE Ø25	D	3		•	•
		PLUNGER 28MM	PISTONE Ø28			•		
34*		COPPER SPACER	ROSETTA RAME	D	3			
35*		PLUNGER ROD	ASTA PISTONE	H	3			
36*		CONNECTING ROD PIN	SPINOTTO	H	3			
37*		CONNECTING ROD	BIELLA	H	3			
38*		SPRING WASHER Ø6	ROSETTA ELASTICA Ø6	H	6			
39*		CONNECTING ROD SCREW M6X30	VITE M6X30	H	6			
40*		"O" RING Ø 2.62X152.07	"O" RING Ø 2.62X152.07	F	1			
41	9.850-389.0	CRANKCASE COVER	COPERCHIO POSTERIORE		1			
42*		"O" RING Ø1.78X14	"O" RING Ø1.78X14	F	1	•	•	•
43*		BRASS PLUG G3/8	TAPPO OTTONE G3/8		1			
44*		SIGHT GLASS, G3/4	SPIA LIVELLO OLIO G3/4	F	1			
45	9.851-474.0	SCREW M6X16	VITE M6X16		4			
46*		VALVE SEAT	SEDE VALVOLA	B-G	6			
47*		VALVE PLATE	PIATTELLO VALVOLA	B-G	6			
48*		VALVE SPRING	MOLLA VALVOLA	B-G	3			
49*		VALVE CAGE	GABBIA VALVOLA	B-G	6			
50*		VALVE SPRING	MOLLA VALVOLA	B-G	3			

